

## Installation and Operating Instructions for Brake Caliper DV 020 FEM

E 09.740e

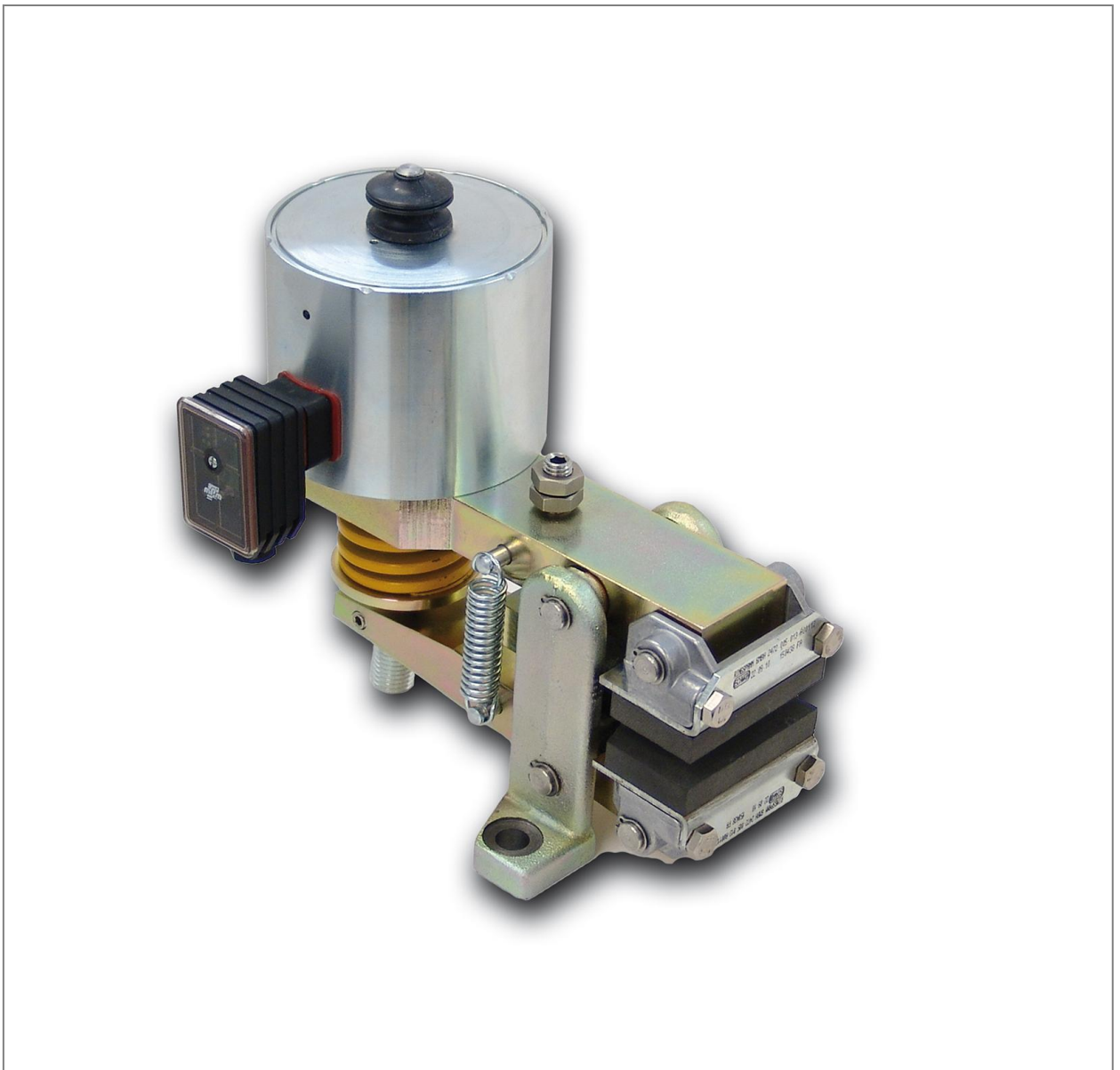

Any questions? Please contact us.

<b>RINGSPANN</b>	<b>Installation and Operating Instructions for Brake Caliper DV 020 FEM spring activated – electromagnetic released</b>	<b>E 09.740e</b>			
Issue: 01.07.2013	Version : 3	drawn: Bn	checked: Ei	Pages: 11	Page: 2

---

## Important

Please read these instructions carefully before installing and operating the product. Your particular attention is drawn to the notes on safety.

These installation and operating instructions are valid on condition that the product meets the selection criteria for its proper use. Selection and design of the product is not the subject of these installation and operating instructions.

Disregarding or misinterpreting these installation and operating instructions invalidates any product liability or warranty by RINGSPANN; the same applies if the product is taken apart or changed.

These installation and operating instructions should be kept in a safe place and should accompany the product if it is passed on to others – either on its own or as part of a machine – to make it accessible to the user.

---

## Safety Notice

- Installation and operation of this product should only be carried out by skilled personnel.
- Repairs may only be carried out by the manufacturer or accredited RINGSPANN agents.
- If a malfunction is indicated, the product or the machine into which it is installed, should be stopped immediately and either RINGSPANN or an accredited RINGSPANN agent should be informed.
- Switch off the power supply before commencing work on electrical components.
- Rotating machine elements must be protected by the purchaser to prevent accidental contact.
- Supplies abroad are subject to the safety laws prevailing in those countries.

<b>RINGSPANN</b>	<b>Installation and Operating Instructions for Brake Caliper DV 020 FEM spring activated – electromagnetic released</b>			<b>E 09.740e</b>	
Issue: 01.07.2013	Version : 3	drawn: Bn	checked: Ei	Pages: 11	Page: 3

## Contents

- 1 General information**
- 2 Configuration and function**
- 3 Drawing and parts list**
- 4 Condition on delivery**
- 5 Installing the RINGSPANN brake caliper**
  - 5.1 Installation
  - 5.2 Brake caliper electrical connection
  - 5.3 Connection of wear alarm cable (optional)
  - 5.4 Brake caliper adjustment
  - 5.5 Running-in procedure
- 6 Maintenance**
  - 6.1 General maintenance
  - 6.2 Checking / adjusting braking force
  - 6.3 Checking brake pad wear
  - 6.4 Emergency release
- 7 Replacement of worn parts**
  - 7.1 Brake pads

<b>RINGSPANN</b>	<b>Installation and Operating Instructions for Brake Caliper DV 020 FEM spring activated – electromagnetic released</b>			<b>E 09.740e</b>	
Issue: 01.07.2013	Version : 3	drawn: Bn	checked: Ei	Pages: 11	Page: 4

## 1. General information

These installation and operating instructions apply to DV 020 FEM (brake caliper mounted parallel to the brake disc):

- with right-mounted brake chamber.
- with left-mounted brake chamber.
- with signal generator.
- various types of brake-pads, e.g. with wear alarm cable, increased glide speed, double friction surface or other special brake pad materials.

Please consult the drawings in each section when using these instructions.

## 2. Configuration and function

The brake caliper is used as a parking and stopping brake.

Braking force is generated by the spring (5). The brake is released (opened) with the aid of an electromagnet (1). Brake pad (2) wear reduces brake holding and stopping force, as it lessens tension in the spring.

If the event of brake pad wear resulting from operation, wear control (see Section 6.3) and a brake torque adjustment (see Section 6.2) are necessary.

The brake caliper is equipped with a lockable “emergency release nut” (8) (see Section 6.4 “Emergency release”).

Rotating parts (e.g. brake discs) must be secured by the purchaser to prevent contact.



### **Danger to life and limb!**

**It is essential to secure the entire drive train against inadvertent starts during brake installation and maintenance. Rotating components can cause severe injuries.**

**Therefore, rotating components (e.g. brake disc) must be secured by the operator to prevent accidental contact.**

### 3. Drawing and parts list

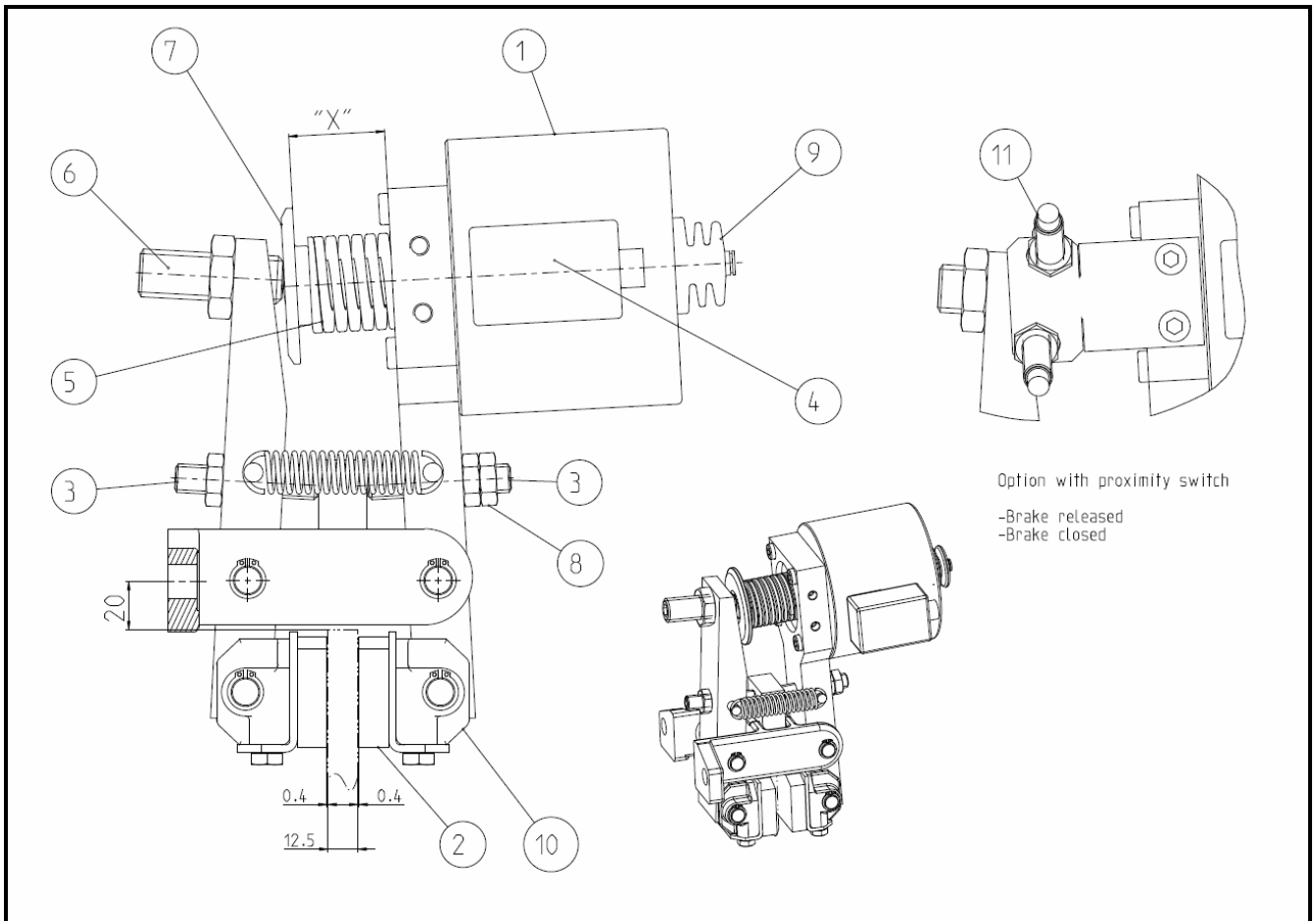

Fig. 3.1

Parts list:

Part	Nomenclature	Quantity	Part number
1	Electromagnet 230 VAC included Pos. 4 electronic 230 VAC	1	3514.014.102.000000
2	Standard brake pad	2	2472.005.013.A00112*
2	Brake pad for parking application	2	2472.005.013.A00117*
4	Electronics 230 VAC	1	3515.072.101.000000
11	Proximity switch, inductive	1	3505.012.001.A00002

\* Part number for 1 brake pad.

For the unique assignment of the identical Parts must specify the part number of the brake on the identification plate.

<b>RINGSPANN</b>	<b>Installation and Operating Instructions for Brake Caliper DV 020 FEM spring activated – electromagnetic released</b>			<b>E 09.740e</b>	
	Issue: 01.07.2013	Version : 3	drawn: Bn	checked: Ei	Pages: 11 Page: 6

#### 4. Condition on delivery

The brake caliper is delivered with a clamping gap of approx. 7.0 mm between brake pads. During operation of the electromagnet, the brake caliper opens to the pre-defined clamping gap of 13.5 mm (brake disc thickness 12.5 plus 0.5 mm gap on each side between the brake disc and the brake pads).

#### 5. Installing the RINGSPANN brake caliper

Before installing the brake, the brake disc must be cleaned with alcohol, e.g. ethyl or isopropyl alcohol, or a water-based surfactant solution (soapy water, etc.) and then rubbed dry with a clean cloth.

When cleaning the brake disc with a thinner, acetone or a brake cleaning agent, it is important to ensure that neither these cleaners nor any cleaner residues come in contact with the brake pads. This is especially important in the case of brakes used only as parking brakes, as no dynamic braking operations take place during which thinner residues would be rubbed off the brake disc.



#### Caution!

Oil and rust-proofing-agent residues reduced friction coefficient and thus diminish transmissible braking torque substantially.

The brake caliper must be released prior to installation on the brake disc with 12.5 mm thickness. This can be accomplished:

- with the aid of the electromagnet, provided it has been connected to a power source (see Section 5.2)
- with the aid of the “emergency release nut” (8), see Section 6.4.



#### Caution! Danger of injury!

With air of the brake calipers the spring (5) becomes set under tension. If the electromagnet not constantly gets the correct current supply, parts of the brake can move suddenly relatively to each other!

#### 5.1 Installation

The brake caliper should be mounted to stable, vibration-free machine components in order to ensure noise-free, non-screech.

During installation, it is essential to ensure that brake pads are centred and in full contact with the brake disc (the midlines of the brake lever must point to the midpoint of the brake disc.). Maximum permissible lateral brake disc wobble is 0.2 mm. Greater wobble may cause rattling and shaking of the brake unit.

The brake caliper is mounted to the machine component with using two M12 bolts (strength class 8.8).

<b>RINGSPANN</b>	<b>Installation and Operating Instructions for Brake Caliper DV 020 FEM spring activated – electromagnetic released</b>			<b>E 09.740e</b>	
	Issue: 01.07.2013	Version : 3	drawn: Bn	checked: Ei	Pages: 11 Page: 7



**Caution!**

If the brake release by screwing the "emergency released nut" (8), the hexagon nut must be removed after the installation of the brake for a functional brake!

5.2 Brake calper electrical connection



**Caution! Danger of damage!**

Before connecting the brake caliper to a power source, ensure that your power supply conforms to the specifications for nominal voltage and power frequency on the identification plate. If voltage and frequency do not conform to specifications, the brake calliper must not be connected to the system, as otherwise the electronics and/or the electrical release may be irreparably damaged.

Nominal voltage: 230 VAC, 50...60 Hz, single-phase.

Circuit-breaker : 6A (**the security with 6A is to be placed by the user surely**).

Cable : up to a length of 50 m: 1.5 mm<sup>2</sup>, fine gage.  
length of 50 m or more: 2.5 mm<sup>2</sup>, fine gage.  
Outside diameter 5....10 mm.

Brief surges of up to 4 A (for a very few 100 ms) occur when the switch is activated.

A step-down transformer may be used to reduce voltage, provided the transformer has a capacity of at least 0.25 kVA.

Connect the main power cable as shown in Fig. 5.1. Ensure that the cable passage is completely sealed in order to prevent the intrusion of water into the terminal box.

L : Phase 1 230 VAC  
N : neutral conductor  
≡ : protection conductor

Resulting operating voltage L and N = 230 VAC.

The connections L and N may be exchanged.



Fig. 5.1



**Caution! Danger of damage!**

Before you take off electronics from the electromagnets, remove supply voltage. During attached supply voltage can the take off of the electronics destroy these.

5.3 Connection of wear alarm cable (optional)

Attach the wear alarm cable e.g. over a signal lamp to 24 V a control voltage. If the maximum brake pad abrasion is reached, the contact comes off to the neutral conductor and the signal lamp lights up.

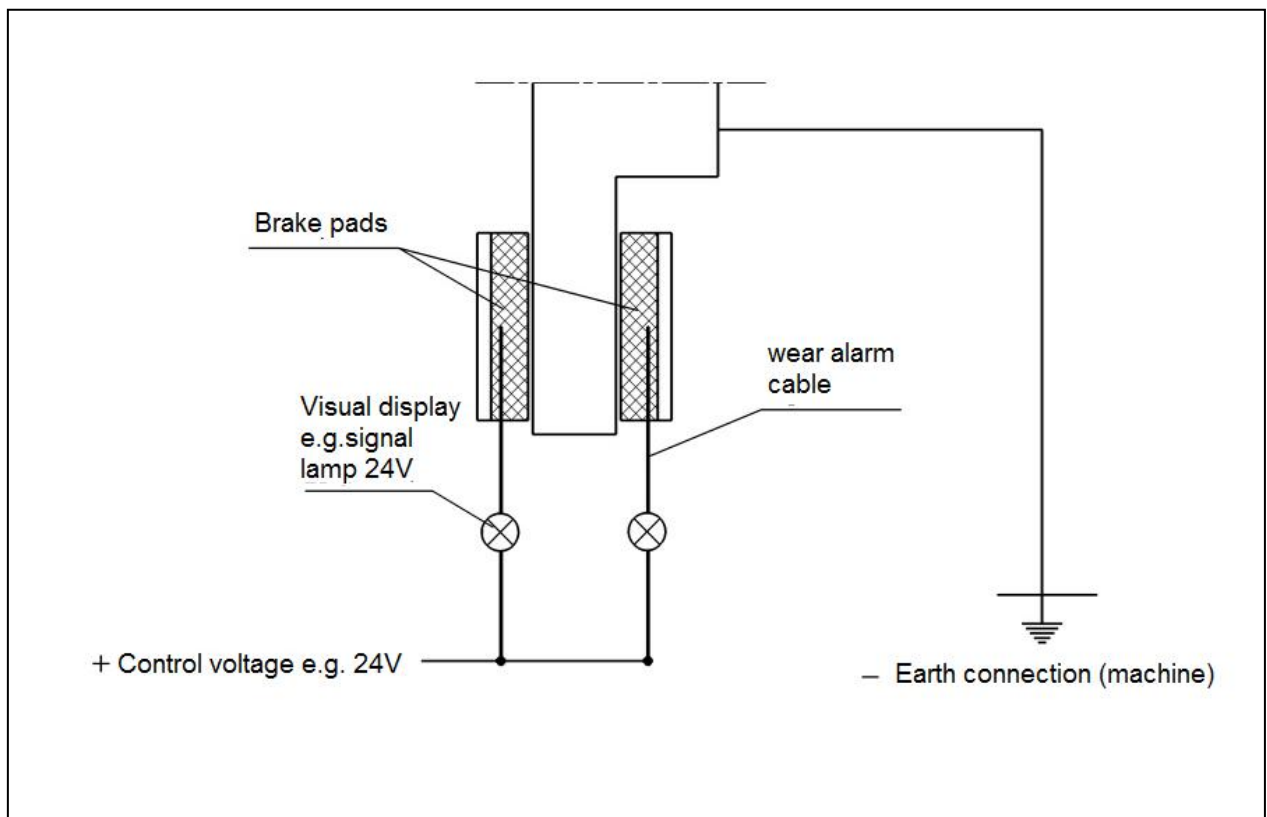

Fig. 5.2



<b>RINGSPANN</b>	<b>Installation and Operating Instructions for Brake Caliper DV 020 FEM spring activated – electromagnetic released</b>	<b>E 09.740e</b>
Issue: 01.07.2013	Version : 3	drawn: Bn    checked: Ei    Pages: 11    Page: 9

#### 5.4 Brake caliper adjustment



#### **Caution!**

The braking/holding force must be adjusted prior to initial operation!

- You should connect the electromagnet on, when connect the electronics to supply voltage.
- Solve the both lock nuts and „the emergency release nut“ and turn you the both threaded pins (3) M12x60 DIN ISO 4026 in the levers counter-clockwise, approx. 2 full turns.
- Turn the screw (6) into the lever, until it abuts against the summit of the magnet anchor. Then set a small gap (0.2 – 0.4 mm) between the two brake pads and the brake disc by tightening further, ensuring that the brake pads do not rub against the disc. It is helpful to press one brake pad against the brake disc and to set the desired total gap between the disc and the other brake pad using a feeler gauge.



#### **Please note!**

The minimum adjustable gap depends on the actual degree of lateral brake disc wobble. Smaller gaps increase the wear reserve, i.e. the interval between brake caliper adjustments.

- Depending on the positions of the brake caliper and the brake disc axle, the laterally mounted electromagnet may generate a tipping force which results in an unequal gap between the two brake pads and the brake disc. In extreme cases, one brake pad may come to rest against the brake disc, while the total gap shifts to the other side of the disc. This causes constant rubbing by this brake pad during operation. The gap can be adjusted (distributed equally) by turning the threaded pins (3). Determine where the gap between a brake pad (brake lever) and the brake disc is larger, then turn the corresponding threaded pin clockwise to set an equal gap on both sides of the disc.



#### **Caution!**

It is necessary to ensure that the friction pads (2) do not grind in the open position of the caliper on the disc!

- Now the brake caliper is de-energized, the full torque (holding torque) are available.

#### 5.5 Running-in procedure

Optimum braking effect is achieved only when both brake pads have full contact with the brake disc and the pads have been heated briefly to approx. 200°C. Therefore, repeated brief braking actions (warm-up) while the brake disc is rotating are recommended.

<b>RINGSPANN</b>	<b>Installation and Operating Instructions for Brake Caliper DV 020 FEM spring activated – electromagnetic released</b>			<b>E 09.740e</b>	
Issue: 01.07.2013	Version : 3	drawn: Bn	checked: Ei	Pages: 11	Page: 10



**Caution!**

If running-in is not performed, the braking forces cited in our catalogue no. 46 cannot be achieved. Reductions of up to 50% are possible!

## 6. Maintenance

Brake calliper maintenance should be performed at intervals of 4 to 12 weeks, depending upon the frequency and duration of operation.

### 6.1 General maintenance

- Check both brake lever for ease of movement.
- Clean all bearings and glide points.
- Lubricate all bearing and glide points.
- Check to ensure that the brake pads do not rub against the brake disc when the brake caliper is open, i.e. hat the gap is uniform on both sides. Adjust the brake gap is required (see Section 5.4).



**Caution!**

Brake pads (2) must not be come in contact with lubricants!

### Check for tight bolt / screw connections:

- Brake calliper to machine component
- Electromagnet at the brake lever
- Brake pads to brake lever (10)

### 6.2 Checking /adjusting braking force

- Check braking force and spring tension.  
When the brake calliper closed, measure the distance between spring control (7) (see fig. 3.1) and brake lever.



**Caution!**

When brake pads are worn, in the closed condition of the brake calipers tension in the spring is reduced increases and the distance `X` between spring control and brake lever (see fig. 3.1) becomes larger. This reduces braking force. At a protrusion distance of 45 mm, at the latest, braking force must be readjusted as described in Section!

<b>RINGSPANN</b>	<b>Installation and Operating Instructions for Brake Caliper DV 020 FEM spring activated – electromagnetic released</b>			<b>E 09.740e</b>	
Issue: 01.07.2013	Version : 3	drawn: Bn	checked: Ei	Pages: 11	Page: 11

### 6.3 Checking brake pad wear

Brake pad material must have a thickness of at least 8 mm (from the top surface of the brake pad to the top surface of the steel mounting plate) Brake pads or brake linings must always be replaced in pairs.

### 6.4 Emergency release

The brake calliper can to be released manually with the help of the “emergency release nut” (8). In addition those rubber sleeve (9) at the back electromagnets take off and screw the “emergency release nut” on the thread of the anchor.



#### **Caution!**

If the brake release by screwing the "emergency released nut" (8), the hexagon nut must be removed after the installation of the brake for a functional brake!

## **7. Replacement of worn parts**

### 7.1 Brake pads

Before replacing brake pads, ensure that the mass held by the brake is secured against movement, as the brake must be released while the brake pads are replaced. You scolded the electromagnet on, the brake opens. Secure with the “emergency release nut” the brake caliper as described in Section 6.4. Turn the screw (6) back, until the brake pads removed and replaced without difficulty and secure you the screw again with the lock nut.

Fixed spanner or ring spanners (SW 13) are required to loosen and tighten screws.

Following replacement of brake pads, braking force and brake gap must be readjusted as described in Section 5.4.



#### **Caution!**

If the brake release by screwing the "emergency released nut" (8) , the hexagon nut must be removed after the installation of the brake for a functional brake!